

Rustler EM 280 PRO

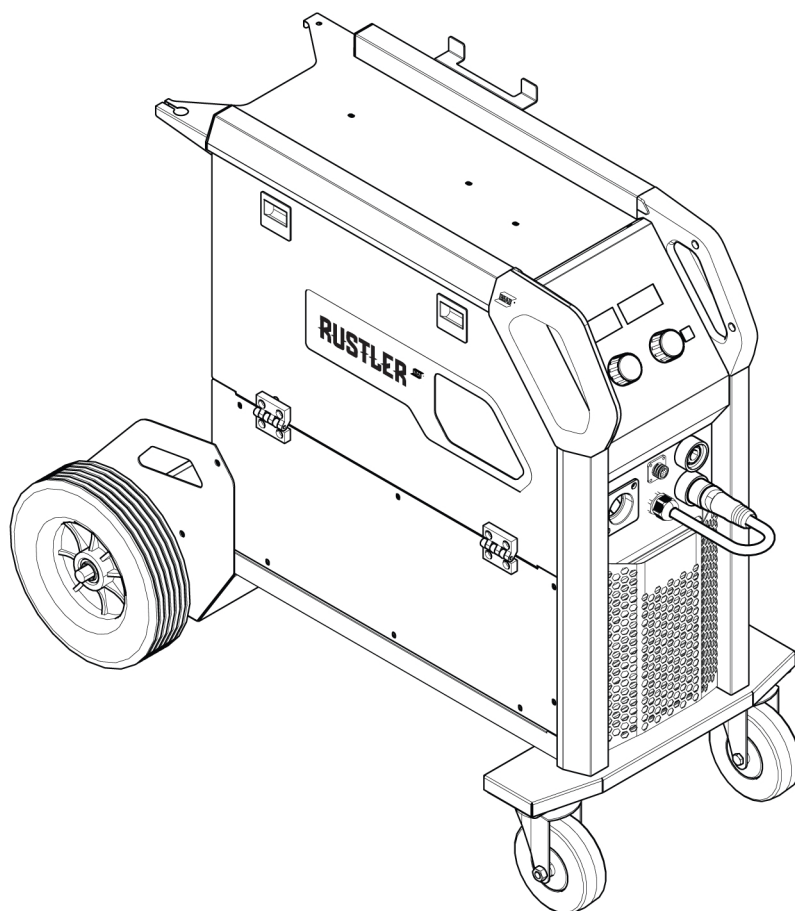

Instruction manual

TABLE OF CONTENTS

1	SAFETY	3
1.1	Meaning of symbols	3
1.2	Safety precautions	3
1.3	User responsibility	6
1.4	California proposition 65 warning	8
2	INTRODUCTION	10
2.1	Equipment	10
3	TECHNICAL DATA	11
4	INSTALLATION	12
4.1	Location	12
4.2	Moving instructions (no lifting)	13
4.3	Mains supply	13
4.4	Supply from power generators	14
5	OPERATION	15
5.1	Connections	15
5.2	Recommended maximum current values for welding and return cables	16
5.3	Connecting welding and return cables	16
5.4	Polarity change	17
5.5	Turning the power on/off	17
5.6	Spool hub brake	17
5.7	Changing and loading wire	18
5.8	Installing wire	19
5.9	Removing wire	21
5.10	Welding with aluminum wire	22
5.11	Changing feed rollers	22
5.12	Removing/ installing/ adjusting the wire guides	22
5.13	Setting feed roll pressure	24
5.14	Shielding gas	25
5.15	Duty cycle	25
6	CONTROL PANEL	27
6.1	User interface	27
6.2	Navigation	27
6.3	LED indicators description	28
6.4	Menu selection in MIG/MAG/GMAW mode	32
7	MAINTENANCE	34
7.1	Routine maintenance	34
7.2	Cleaning the power source	35
7.3	Inspection, cleaning, and replacement	36
8	ERROR CODES	37
8.1	Error code descriptions	37
9	TROUBLESHOOTING	38
10	ORDERING SPARE PARTS	39
	WIRING DIAGRAM	40
	ORDERING NUMBERS	41
	WEAR PARTS	42
	ACCESSORIES	44

1 SAFETY

1.1 Meaning of symbols

As used throughout this manual: Means Attention! Be Alert!



DANGER!

Means immediate hazards which, if not avoided, will result in immediate, serious personal injury or loss of life.



WARNING!

Means potential hazards which could result in personal injury or loss of life.



CAUTION!

Means hazards which could result in minor personal injury.



WARNING!

Before use, read and understand the instruction manual and follow all labels, employer's safety practices and Safety Data Sheets (SDSs).

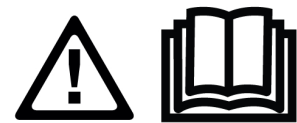

1.2 Safety precautions



WARNING!

These Safety Precautions are for your protection. They summarize precautionary information from the references listed in the Additional Safety Information section. Before performing any installation or operating procedures, be sure to read and follow the safety precautions listed below as well as all other manuals, material safety data sheets, labels, etc. Failure to observe Safety Precautions can result in injury or death.



PROTECT YOURSELF AND OTHERS

Some welding, cutting and gouging processes are noisy and require ear protection. The arc, like the sun, emits ultraviolet (UV) and other radiation and can injure skin and eyes. Hot metal can cause burns. Training in the proper use of the processes and equipment is essential to prevent accidents. Therefore:

1. Wear a welding helmet fitted with a proper shade of filter to protect your face and eyes when welding or watching.
2. Always wear safety glasses with side shields in any work area, even if welding helmets, face shields and goggles are also required.
3. Use a face shield fitted with the correct filter and cover plates to protect your eyes, face, neck and ears from sparks and rays of the arc when operating or observing operations. Warn bystanders not to watch the arc and not to expose themselves to the rays of the electric-arc or hot metal.
4. Wear flameproof gauntlet type gloves, heavy long-sleeve shirt, cuffless trousers, high-topped shoes and a welding helmet or cap for protection, to protect against arc rays and hot sparks or hot metal. A flameproof apron may also be desirable as protection against radiated heat and sparks.
5. Hot sparks or metal can lodge in rolled up sleeves, trouser cuffs, or pockets. Sleeves and collars should be kept buttoned and open pockets eliminated from the front of clothing.
6. Protect other personnel from arc rays and hot sparks with a suitable non-flammable partition or curtains.
7. Use goggles over safety glasses when chipping slag or grinding. Chipped slag may be hot and can fly far. Bystanders should also wear goggles over safety glasses.



FIRES AND EXPLOSIONS

Heat from flames and arcs can start fires. Hot slag or sparks can also cause fires and explosions. Therefore:

1. Protect yourself and others from flying sparks and hot metal.
2. Remove all combustible materials well away from the work area or cover the materials with a protective non-flammable covering. Combustible materials include wood, cloth, sawdust, liquid and gas fuels, solvents, paints and coatings paper, etc.
3. Hot sparks or hot metal can fall through cracks or crevices in floors or wall openings and cause a hidden smoldering fire or fires on the floor below. Make certain that such openings are protected from hot sparks and metal.
4. Do not weld, cut or perform other hot work until the work piece has been completely cleaned so that there are no substances on the work piece which might produce flammable or toxic vapors. Do not do hot work on closed containers, they may explode.
5. Have fire extinguishing equipment handy for instant use, such as a garden hose, water pail, sand bucket, or portable fire extinguisher. Be sure you are trained in its use.
6. Do not use equipment beyond its ratings. For example, an overloaded welding cable can overheat and create a fire hazard.
7. After completing operations, inspect the work area to make certain there are no hot sparks or hot metal which could cause a later fire. Use fire watchers when necessary.



ELECTRICAL SHOCK

Contact with live electrical parts and ground can cause severe injury or death. DO NOT use AC welding current in damp areas, if movement is confined, or if there is danger of falling. Therefore:

1. Be sure the power source frame (chassis) is connected to the ground system of the input power.
2. Connect the workpiece to a good electrical ground.
3. Connect the work cable to the workpiece. A poor or missing connection can expose you or others to a fatal shock.
4. Use well-maintained equipment. Replace worn or damaged cables.
5. Keep everything dry, including clothing, work area, cables, torch/electrode holder and power source.
6. Make sure that all parts of your body are insulated from both the work piece and from the ground.
7. Do not stand directly on metal or the earth while working in tight quarters or a damp area; stand on dry boards or an insulating platform and wear rubber-soled shoes.
8. Put on dry, hole-free gloves before turning on the power.
9. Turn off the power before removing your gloves.
10. Refer to ANSI/ASC Standard Z49.1 for specific grounding recommendations. Do not mistake the work lead for a ground cable.



ELECTRIC AND MAGNETIC FIELDS

May be dangerous. Electric current flowing through any conductor causes localized Electric and Magnetic Fields (EMF). Welding and cutting current creates EMF around welding cables and welding machines. Therefore:

1. Welders with pacemakers should consult their physician before welding. EMF may interfere with some pacemakers.
2. Exposure to EMF may have other health effects which are unknown.

3. Welders should use the following procedures to minimize exposure to EMF:
 - a) Route the electrode and work cables together. Secure them with tape when possible.
 - b) Never coil the torch or work cable around your body.
 - c) Do not place your body between the torch and work cables. Route cables on the same side of your body.
 - d) Connect the work cable to the workpiece as close as possible to the area being welded.
 - e) Keep welding power source and cables as far away from your body as possible.



FUMES AND GASES

Fumes and gases can cause discomfort or harm, particularly in confined spaces. Shielding gases can cause asphyxiation. Therefore:

1. Keep your head out of the fumes. Do not breathe the fumes and gases.
2. Always provide adequate ventilation in the work area by natural or mechanical means. Do not weld, cut or gouge on materials such as galvanized steel, stainless steel, copper, zinc, lead, beryllium or cadmium unless positive mechanical ventilation is provided. Do not breathe fumes from these materials.
3. Do not operate near degreasing and spraying operations. The heat or arc can react with chlorinated hydrocarbon vapors to form phosgene, a highly toxic gas, and other irritant gases.
4. If you develop momentary eye, nose or throat irritation while operating, this is an indication that ventilation is not adequate. Stop work and take necessary steps to improve ventilation in the work area. Do not continue to operate if physical discomfort persists.
5. Refer to ANSI/ASC Standard Z49.1 for specific ventilation recommendations.



CYLINDER HANDLING

Cylinders, if mishandled, can rupture and violently release gas. A sudden rupture of cylinder valve or relief device can injure or kill. Therefore:

1. Locate cylinders away from heat, sparks and flames. Never strike an arc on a cylinder.
2. Use the proper gas for the process and use the proper pressure reducing regulator designed to operate from the compressed gas cylinder. Do not use adapters. Maintain hoses and fittings in good condition. Follow manufacturer's operating instructions for mounting regulator to a compressed gas cylinder.
3. Always secure cylinders in an upright position by chain or strap to suitable hand trucks, undercarriages, benches, wall, post or racks. Never secure cylinders to work tables or fixtures where they may become part of an electrical circuit.
4. When not in use, keep cylinder valves closed. Have valve protection cap in place if regulator is not connected. Secure and move cylinders by using suitable hand trucks.



MOVING PARTS

Moving parts, such as fans, rotors and belts can cause injury. Therefore:

1. Keep all doors, panels, guards and covers closed and securely in place.
2. Have only qualified people remove covers for maintenance and troubleshooting as necessary.
3. Keep hands, hair, loose clothing and tools away from moving parts.
4. Reinstall panels or covers and close doors when service is finished and before starting the unit.

**NOISE**

Excessive noise can damage hearing. Therefore:

Protect your ears. Use ear defenders or other hearing protection.

**HOT SURFACE**

Parts can burn. Therefore:

- Do not touch parts bare handed.
- Allow cooling period before working on equipment.
- To handle hot parts, use proper tools and/or insulated welding gloves to prevent burns.

**WARNING!
FALLING EQUIPMENT CAN INJURE**

- Only use lifting eye to lift unit. Do NOT use running gear, gas cylinders or any other accessories.
- Use equipment of adequate capacity to lift and support unit.
- If using lift forks to move unit, be sure forks are long enough to extend beyond opposite side of unit.
- Keep cables and cords away from moving vehicles when working from an aerial location.

**WARNING!
EQUIPMENT MAINTENANCE**

Faulty or improperly maintained equipment can cause injury or death. Therefore:

1. Always have qualified personnel perform the installation, troubleshooting and maintenance work. Do not perform any electrical work unless you are qualified to perform such work.
2. Before performing any maintenance work inside a power source, disconnect the power source from the incoming electrical power.
3. Maintain cables, earthing wire, connections, power cord and power supply in safe working order. Do not operate any equipment in faulty condition.
4. Do not abuse any equipment or accessories. Keep equipment away from heat sources such as furnaces, wet conditions such as water puddles, oil or grease, corrosive atmospheres and inclement weather.
5. Keep all safety devices and cabinet covers in position and in good repair.
6. Use equipment only for its intended purpose. Do not modify it in any manner.

1.3 User responsibility

Users of ESAB equipment have the ultimate responsibility for ensuring that anyone who works on or near the equipment observes all the relevant safety precautions. Safety precautions must meet the requirements that apply to this type of equipment. The following recommendations should be observed in addition to the standard regulations that apply to the workplace.

All work must be carried out by trained personnel well-acquainted with the operation of the equipment. Incorrect operation of the equipment may lead to hazardous situations which can result in injury to the operator and damage to the equipment.

1. Anyone who uses the equipment must be familiar with:
 - its operation
 - location of emergency stops
 - its function
 - relevant safety precautions
 - welding and cutting or other applicable operation of the equipment

2. The operator must ensure that:
 - no unauthorized person is stationed within the working area of the equipment when it is started up
 - no-one is unprotected when the arc is struck or work is started with the equipment
3. The workplace must:
 - be suitable for the purpose
 - be free from drafts
4. Personal safety equipment:
 - Always wear recommended personal safety equipment, such as safety glasses, flame-proof clothing, safety gloves
 - Do not wear loose-fitting items, such as scarves, bracelets, rings, etc., which could become trapped or cause burns
5. General precautions:
 - Make sure the return cable is connected securely
 - Work on high voltage equipment **may only be carried out by a qualified electrician**
 - Appropriate fire extinguishing equipment must be clearly marked and close at hand
 - Lubrication and maintenance must **not** be carried out on the equipment during operation



WARNING!

Arc welding and cutting can be injurious to yourself and others. Take precautions when welding and cutting.



ELECTRIC SHOCK - Can kill

- Install and ground the unit in accordance with instruction manual.
- Do not touch live electrical parts or electrodes with bare skin, wet gloves or wet clothing.
- Insulate yourself from work and ground.
- Ensure your working position is safe



ELECTRIC AND MAGNETIC FIELDS - Can be dangerous to health

- Welders with pacemakers should consult their physician before welding. EMF may interfere with some pacemakers.
- Exposure to EMF may have other health effects which are unknown.
- Welders should use the following procedures to minimize exposure to EMF:
 - Route the electrode and work cables together on the same side of your body. Secure them with tape when possible. Do not place your body between the torch and work cables. Never coil the torch or work cable around your body. Keep welding power source and cables as far away from your body as possible.
 - Connect the work cable to the workpiece as close as possible to the area being welded.



FUMES AND GASES - Can be dangerous to health

- Keep your head out of the fumes.
- Use ventilation, extraction at the arc, or both, to take fumes and gases away from your breathing zone and the general area.



ARC RAYS - Can injure eyes and burn skin

- Protect your eyes and body. Use the correct welding screen and filter lens and wear protective clothing.
- Protect bystanders with suitable screens or curtains.



NOISE - Excessive noise can damage hearing

Protect your ears. Use earmuffs or other hearing protection.



MOVING PARTS - Can cause injuries

- Keep all doors, panels, guards, and covers closed and securely in place.
- Have only qualified people remove covers for maintenance and troubleshooting as necessary.



- Keep hands, hair, loose clothing and tools away from moving parts.
- Reinstall panels or covers and close doors when service is finished and before starting the unit.



FIRE HAZARD

- Sparks (spatter) can cause fire. Make sure that there are no inflammable materials nearby.
- Do not use on closed containers.



HOT SURFACE - Parts can burn

- Do not touch parts bare handed.
- Allow cooling period before working on equipment.
- To handle hot parts, use proper tools and/or insulated welding gloves to prevent burns.



CAUTION!

This product is solely intended for arc welding.



CAUTION!

Class A equipment is not intended for use in residential locations where the electrical power is provided by the public low-voltage supply system. There may be potential difficulties in ensuring electromagnetic compatibility of class A equipment in those locations, due to conducted as well as radiated disturbances.

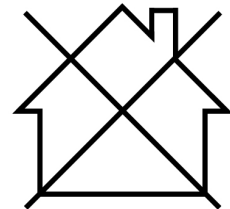

NOTE!

Dispose of electronic equipment at the recycling facility!

In observance of European Directive 2012/19/EC on Waste Electrical and Electronic Equipment and its implementation in accordance with national law, electrical and/or electronic equipment that has reached the end of its life must be disposed of at a recycling facility.

As the person responsible for the equipment, it is your responsibility to obtain information on approved collection stations.

For further information contact the nearest ESAB dealer.

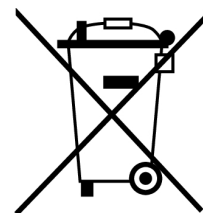

1.4 California proposition 65 warning



WARNING!

Welding or cutting equipment produces fumes or gases which contain chemicals known in the State of California to cause birth defects and, in some cases, cancer. (California Health & Safety Code Section 25249.5 et seq.)



WARNING!

This product can expose you to chemicals including lead, which are known to the state of California to cause cancer and birth defects or other reproductive harm. Wash hands after use.

For more information, go to www.P65Warnings.ca.gov.

ESAB has an assortment of welding accessories and personal protection equipment for purchase. For ordering information contact your local ESAB dealer or visit us on our website.

2 INTRODUCTION

The **Rustler EM 280 PRO** is a compact welding power source intended for welding with solid wires, flux cored wires (MIG/MAG/GMAW, FCAW).

The equipment has built-in wheels and a gas bottle bracket to move easily around the work place and provide a better reach.

Main features of Rustler EM 280 PRO:

- High output current and duty cycle
- Easy and intuitive set up
- Durable housing
- Superb arc characteristic, optimized for most common based materials

ESAB accessories for the product can be found in the "ACCESSORIES" chapter of this manual.

2.1 Equipment

The power source is supplied with:

- Spray Master 250 MIG Torch 12 ft. (3.6 m)
- Work lead with clamp, 300 A, 15 ft. (4.6 m)
- Torch hanger
- Cable hanger
- Regulator/flow gauge
- Gas hose 13.1 ft. (4.0 m)
- Drive rolls for 0.030/0.035 in. (0.8/0.9 mm) V (spare)
- Drive rolls for 0.035/0.045 in. (0.9/1.2 mm) V (fitted)
- Instruction manual
- Quick start guide

3 TECHNICAL DATA

	EM 280 PRO	
Outlet voltage	208 V \pm 15%, 1 Φ 50/60 Hz	230 V \pm 15%, 1 Φ 50/60 Hz
Primary current	47 A	43 A
I_{eff}	21.0 A	21.5 A
Idle power	<50 W	
Permissible load		
20% duty cycle	280 A / 28 V	-
25% duty cycle	-	280 A / 28 V
40% duty cycle	198 A / 23.9 V	234 A / 25.7 V
60% duty cycle	162 A / 22.1 V	200 A / 24 V
100% duty cycle	125 A / 20.25 V	155 A / 21.75 V
Power factor at maximum current	>0.98	
Efficiency at maximum current	>82%	
Open-circuit voltage	68 V	
Operating temperature	+14 to 104°F (-10 to +40°C)	
Storage and transportation temperature	-4 to 131°F (-20 to +55°C)	
Constant sound pressure when idling	<75 db	
Wire feed speed range	2-17 m/min (80-680 ipm)	
Amperage range	30-280 A	
Voltage range	12-30 V	
Wire spool size	8 in. (200 mm) 12 in. (300 mm)	
Wire diameter	GMAW: 0.030, 0.035, 0.040, 0.045 in. (0.8, 0.9, 1.0, 1.2 mm) FCAW: 0.030, 0.035, 0.040, 0.045 in. (0.8, 0.9, 1.0, 1.2 mm)	
Material thickness range	GMAW/Flux-cored Mild steel: 24 ga. - 1/2 in. (0.5–13.0 mm) Aluminum: 18 ga. - 3/8 in. (1.2–10 mm) Stainless: 20 ga. - 1/4 in. (1.0–6.0 mm)	
Dimensions l × w × h	37.8 x 17.8 x 33.1 in. (960 × 450 × 840 mm)	
Weight	133 lbs (60 kg)	
Enclosure class	IP21	

Duty cycle

The duty cycle refers to the time as a percentage of a ten-minute period that you can weld or cut at a certain load without overloading. The duty cycle is valid for 104 °F (40 °C), or below.

Enclosure class

The **IP** code indicates the enclosure class, i.e. the degree of protection against penetration by solid objects or water.

Equipment marked **IP21** is intended for indoor use.

4 INSTALLATION

The installation must be carried out by a professional.



CAUTION!

This product is intended for industrial use. In a domestic environment this product may cause radio interference. It is the user's responsibility to take adequate precautions.



CAUTION!

Remove any packaging material prior to use. Do not block the air vents at the front or rear of the welding power source.

4.1 Location

Position the power source so that cooling air inlets and outlets are not obstructed.

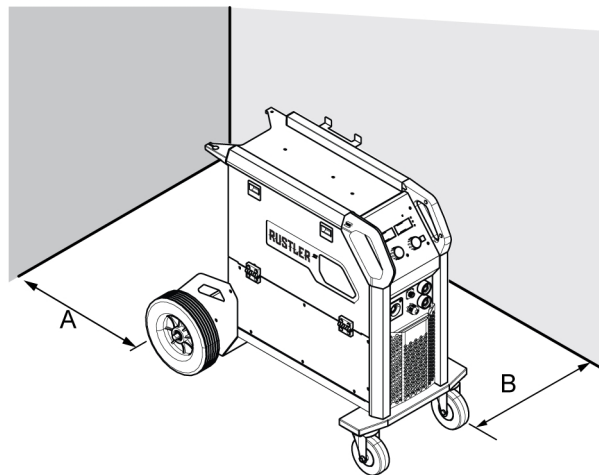

A. Minimum 8 in. (200 mm)

B. Minimum 8 in. (200 mm)



WARNING!

Electric shock! Do not touch the workpiece or the welding head during operation!



WARNING!

Secure the equipment - particularly if the ground is uneven or sloping.

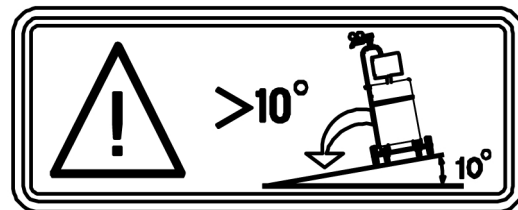

NOTE!

When moving the equipment use intended handle. Never pull the cables.

4.2 Moving instructions (no lifting)

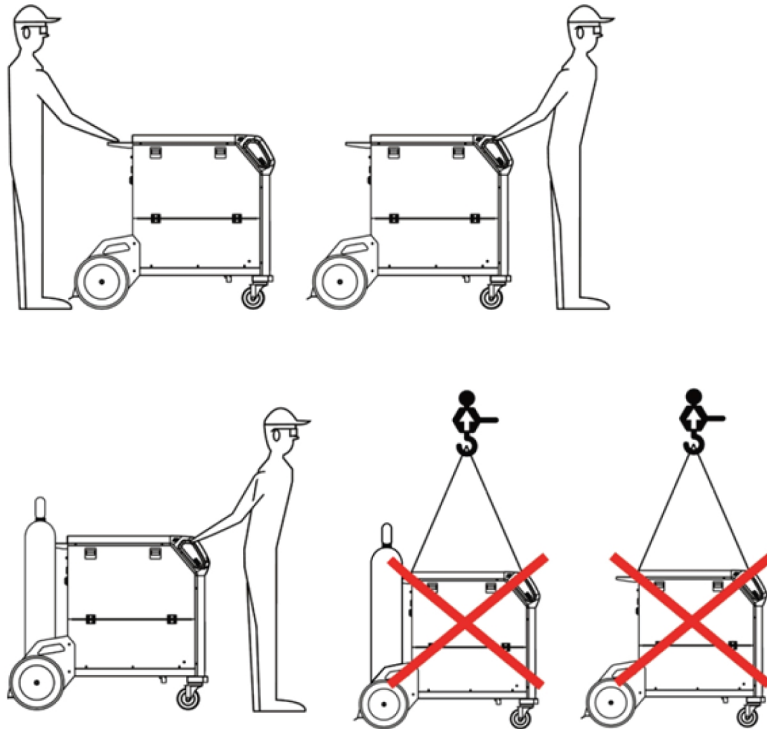

4.3 Mains supply



NOTE!

The supply voltage should be 208 V / 230 V AC $\pm 15\%$. Too low of supply voltage may cause poor welding performance. Too high of welding supply voltage will cause components to overheat and possibly fail. Contact the local electric utility for information about the type of electrical service available, how proper connections should be made, and inspection required.

The welding power source must be:

- Correctly installed, if necessary, by a qualified electrician.
- Correctly earthed (electrically) in accordance with local regulations.
- Connected to the correct size power point and fuse as indicated in table below

1. Rating plate with supply connection data.

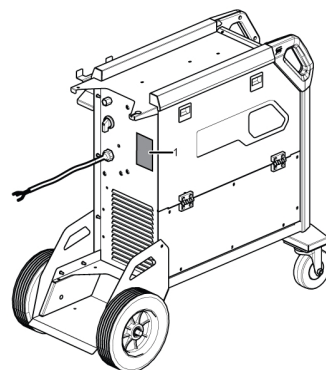

Recommended fuse sizes and minimum cable area		
Mains voltage	EM 280 PRO	
	208 ±15%, 1Φ50/60 Hz	230 V ±15%, 1Φ50/60 Hz
Mains cable area	3/10 AWG (6.0 mm ²), 14.8 ft. (4.5 m)	
Maximal current rating I_{max} GMAW	47 A	43 A
I_{1eff}	21.0 A	21.5 A
Maximum recommended fuse* or circuit breaker rating * Time delay fuse	25 A	
Maximum recommended extension cord length	328 ft. (100 m)	
Minimum recommended extension cord size	12 ft. (3.6 m)	

4.4 Supply from power generators

The power source can be supplied from different types of generators. However, some generators may not provide sufficient power for the welding power source to operate correctly. Generators with Automatic Voltage Regulation (AVR) or with equivalent or better type of regulation, with rated power 9.8 KW, are recommended.

5 OPERATION

General safety regulations for handling the equipment can be found in the "SAFETY" chapter of this manual. Read it through before you start using the equipment!



WARNING!

Electric shock! Do not touch the workpiece or the welding head during operation!

5.1 Connections

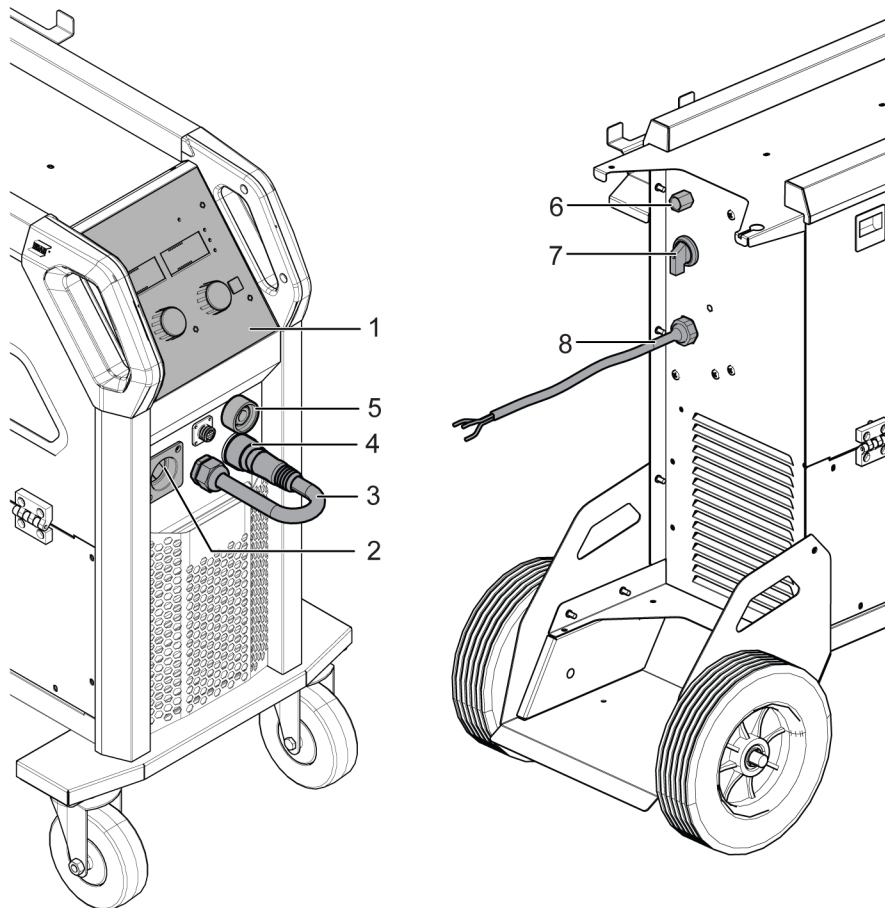

- | | |
|--|------------------------------------|
| 1. User interface | 5. Electrode positive terminal (+) |
| 2. MIG / MAG / GMAW torch and spool gun connection | 6. Gas inlet |
| 3. Polarity changeover cable | 7. Mains supply switch, ON/OFF |
| 4. Electrode negative terminal (-) | 8. Mains supply cable |

5.2 Recommended maximum current values for welding and return cables

Recommended cable sizes

Output current(A)	Duty cycle 100%		Duty cycle 60%		Duty cycle 30%	
	Effective output current (A)	Welding cable section AWG (mm ²)	Effective output current (A)	Welding cable section AWG (mm ²)	Effective output current (A)	Welding cable section AWG (mm ²)
60	60	8 (10)	46	8 (10)	33	10 (6)
80	80	8 (10)	62	8 (10)	44	10 (6)
100	100	8 (13)	77	8 (10)	55	8 (10)
120	120	6 (16)	93	8 (13)	66	8 (10)
140	140	6 (16)	108	6 (16)	77	8 (10)
160	160	4 (25)	124	6 (16)	88	8 (13)
180	180	4 (25)	139	4 (25)	98	6 (16)
200	200	4 (25)	155	4 (25)	109	6 (16)
250	250	2 (35)	194	4 (25)	137	4 (25)
300	300	2 (35)	232	2 (35)	164	4 (25)
350	350	1 (50)	271	2 (35)	191	2 (35)
400	400	1 (50)	310	1 (50)	219	2 (35)
500	500	2/0 (70)	387	2/0 (70)	274	1 (50)
600	600	2/5 (75)	464	2/0 (70)	328	1 (50)
800	800	3/0 (95)	619	3/0 (95)	438	2/0 (70)
1000	1000	2/0 (70)	774	2/0 (70) × 2	547	3/0 (95)
1250	1250	3/0 (95) × 2	968	3/0 (70) × 2	684	2/0 (70)

5.3 Connecting welding and return cables

The power source has two outputs, a positive welding terminal (+) and a negative welding terminal (-), for connecting welding and return cables. The output to which the welding cable is connected depends on the welding process or type of electrode used.

- For MIG/MAG/GMAW welding, the welding cable can be connected to the positive welding terminal (+) or negative welding terminal (-), depending on the type of electrode used. The connection polarity is stated on the electrode packaging.

5.4 Polarity change

The polarity changeover cable is used to select the correct polarity for the weld output. The correct polarity is determined by the wire that has been selected to complete the weld. To configure the power source to operate with electrode positive insert and secure the polarity changeover cable into the positive [+] terminal and the return lead into the negative [-] terminal. Be sure that the connections are tight. Secure the work clamp to the work piece in a clean, debris-free location.



NOTE!

For some wires, it is recommended to use negative polarity such as self-shielded flux-core. See wire manufacturers recommendation

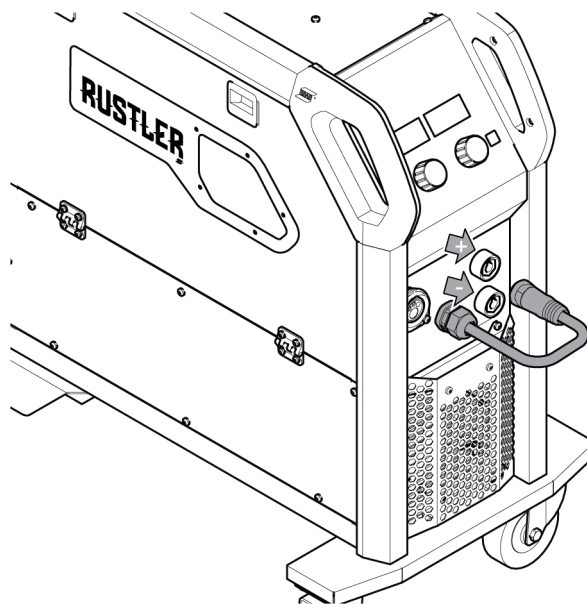

5.5 Turning the power on/off



CAUTION!

Do not turn off the power source during welding (with load).

- 1) Turn on the power by turning the switch to the "ON" (I) position.
- 2) Turn the unit off by turning the switch to the "O" position.

Whether the mains power supply is interrupted or the power source is switched off in the normal manner, weld programs are stored so that they are available next time the unit is started.

5.6 Spool hub brake

The spool hub brake force should be adjusted to prevent wire overrun. The actual brake force needed is dependent on the wire feed speed and the size and weight of the wire spool.

Do not overload the spool hub brake! A high brake force may overload the motor and reduce motor life and result in poor weld quality.

- 1) The spool hub brake force can be adjusted by rotating the 6-mm hexagon Allen screw in the middle of the brake hub nut.

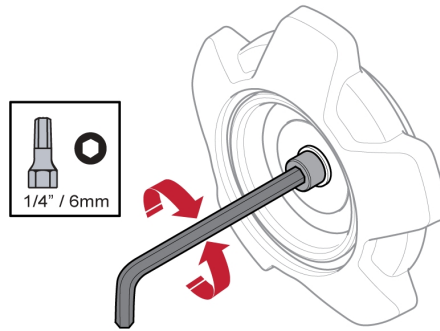

The wire reel hub incorporates a friction brake which is adjusted during manufacture for optimum braking. If it is considered necessary, adjustment can be made by turning the hex head screw inside the open end of the hub clockwise to tighten the brake. Correct adjustment will result in the wire reel circumference continuing no further than 1/8–3/16 in. (3-5 mm) after release of the trigger. The electrode wire should be slack without becoming dislodged from wire spool.

5.7 Changing and loading wire

- 1) Open the left door of the power source.
- 2) Remove the brake hub nut and remove the wire spool.
- 3) Insert a new wire spool into the unit by placing the spool of wire on the spool hub.
- 4) Secure the spool of wire on the spool hub, by tightening the brake hub nut.
- 5) Straighten out the new welding wire 4–8 in. (10–20 cm) and thread the wire through the wire feeder mechanism.

6) Close and latch the door.

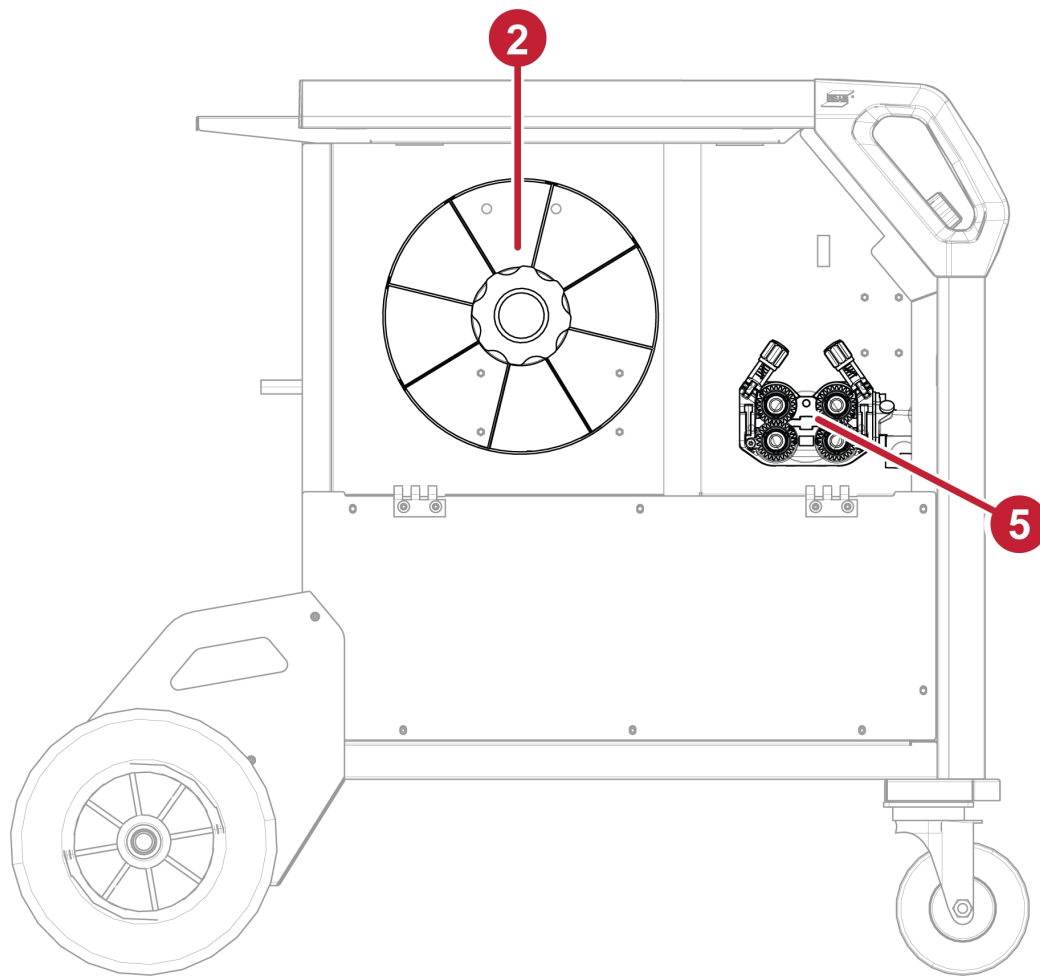

5.8 Installing wire



CAUTION!

Too long a torch liner risks damage to the wire-feed assembly if forced to fit when attempting to connect the torch to the power unit.

Refer to the torch manual for instructions for torch liner replacement.

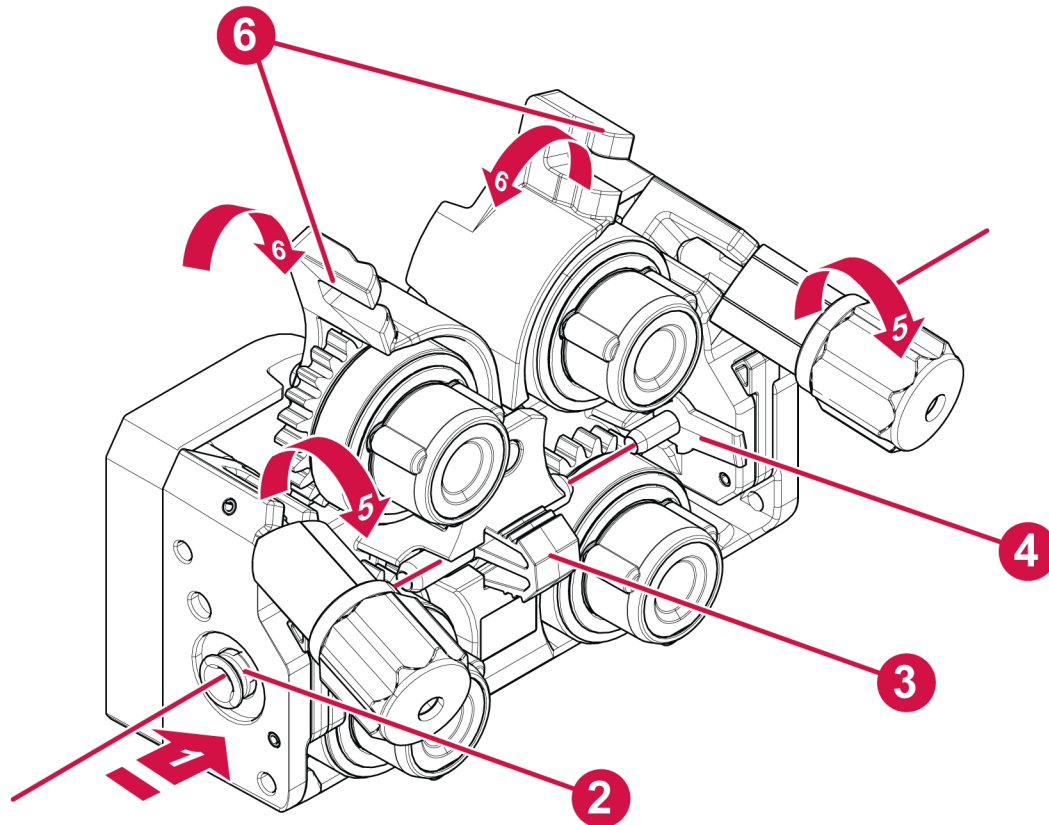

- | | |
|----------------------------|---------------------------|
| 1. Wire from spool | 4. Wire outlet guide |
| 2. Wire inlet guide | 5. Tensioner arm |
| 3. Intermediate wire guide | 6. Feed roll pressure arm |

- 1) Open the wire spool side cover of the power source.
- 2) Install the new wire spool on to the spool hub.
- 3) Release the tensioner arm by pulling the tensioner arm up out of its detent and rotating it outward. The feed roll pressure arm will spring up.
- 4) Install rollers for selected wire size.
- 5) With a clean-cut, pull the wire from the wire spool and feed it into the wire inlet guide across the rear feed roll; through the center wire guide; across the front feed roll and into the wire outlet guide. Thread enough wire that it will extend past the front of the wire feed unit.
- 6) Close the drive roll pressure and secure the rear and front tensioner arms to secure wire in place.
- 7) Connect the torch assembly to the unit by inserting the end of the wire into torch connector and secure the torch in the drive assembly with the torch retention thumb screw.
- 8) Power up the power source.
- 9) With the torch cable laid out straight, feed the wire through the torch cable until the wire is visible at the end of the torch by pressing the jog switch or trigger switch on the torch.
- 10) Set and verify the wire feed tension for correct wire feed pressure, see "Setting wire feed pressure" chapter.

After completion, close the wire spool side cover of the power source.

5.9 Removing wire

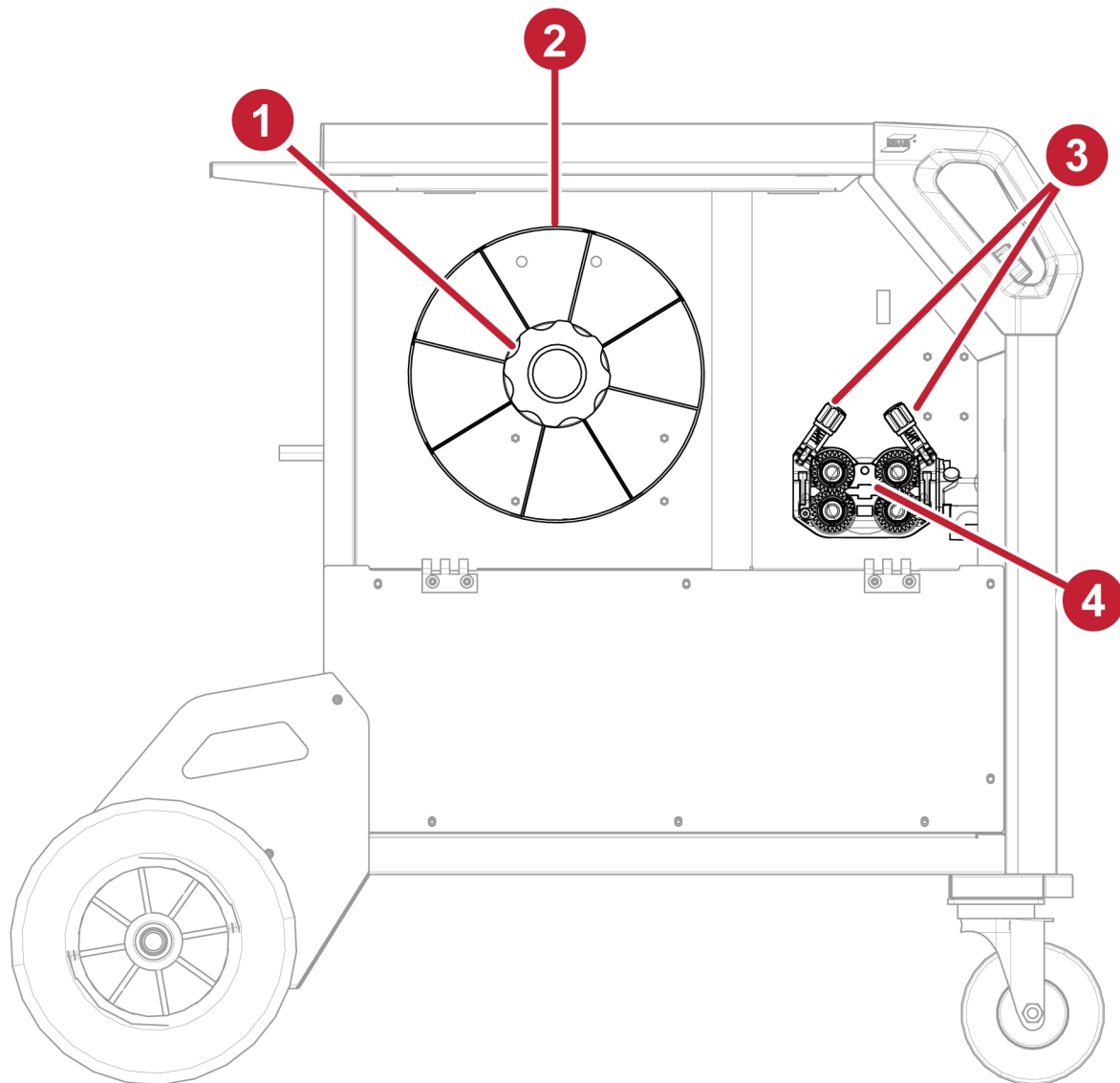

- | | |
|-----------------------|------------------------|
| 1. Wire retention nut | 3. Tensioner arm |
| 2. Wire spool | 4. Wire drive assembly |

- 1) Open the wire spool side cover of the power source.
- 2) Release the tensioner arms by pulling it up out of its detent and rotating it outward.
- 3) Cut the wire at the end of the torch near the contact tip.
- 4) Secure the wire by hand between the wire spool and the wire inlet guide.
- 5) Manually rewind the wire spool. Pay attention to not release the end of the wire and unwind the spool.
- 6) Secure the end of the wire to the wire spool basket or plastic spool.
- 7) Remove wire retention nut.
- 8) Remove wire spool.

5.10 Welding with aluminum wire



NOTE!

Make sure to use the correct size contact tip, feed rolls, wire guides, and torch liner specific to aluminum.

To weld aluminum using the standard supplied torch, refer to MIG / MAG / GMAW torch instruction manual for replacing standard steel torch conduit liner with a teflon torch conduit liner. To MIG / MAG / GMAW weld with aluminum wire, use optional spool gun or push-pull torch for the best results. Refer to the specific torch instruction manual for the correct set up.

5.11 Changing feed rollers

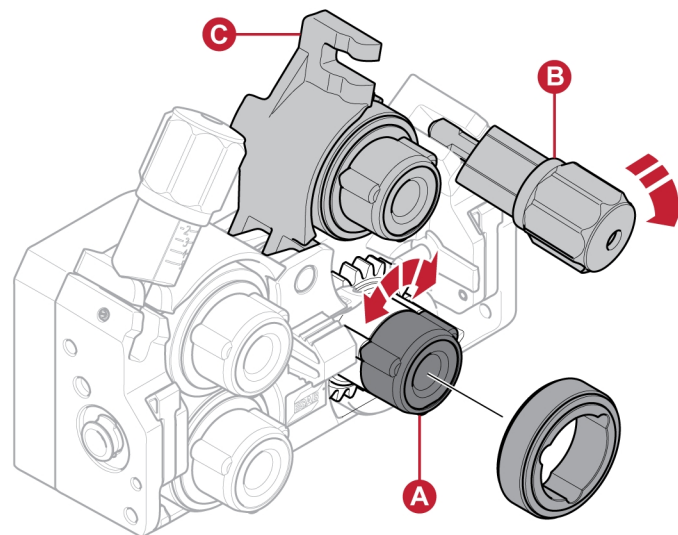

When changing to a different type or size of wire, the feed rollers should be changed to match the new type or size of wire. For information about correct feed rolls, see the WEAR PARTS appendix.

- 1) Open the wire spool side cover of the power source.
- 2) Unlock the feed rolls by rotating the feed roll quick lock (A) for each feed roll.
- 3) Remove the pressure from the feed roll pressure arms (C) by rotating the wire tensioner arm outward.
- 4) Remove the feed rolls and install the new ones.
- 5) Reapply pressure to the feed rolls, by pushing the feed roll pressure arms (C) down and secure them with the tensioner arms (B).
- 6) Lock the feed rolls by rotating the feed roll quick locks (A).
- 7) Close the wire spool side cover of the power source.

5.12 Removing/ installing/ adjusting the wire guides

There are three wire guides: wire inlet guide, middle wire guide, and wire outlet guide. The wire inlet guide and middle wire guide are common for all wire types and diameters.

When changing to a different type of wire, the wire guides may need to be changed to match the new type of wire. For information about the correct wire guides depending on wire diameter and type, see the "WEAR PARTS" appendix.

Wire inlet guides

- 1) Unlock the wire inlet guide quick lock (A) by folding it out.
- 2) Remove the wire inlet guide (B).
- 3) Fit the correct wire inlet guide (according to the WEAR PARTS appendix).
- 4) Lock the new wire inlet guide into place using the wire guide quick lock (A).

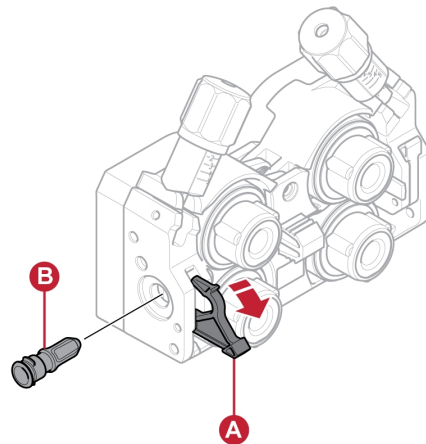
**Intermediate wire guide**

- 1) To remove the middle wire guide, pinch the middle of the wire guide and pull out the guide (A).
- 2) To install the middle wire guide, pinch the guide and push it into place. The clips locks the guide into place.

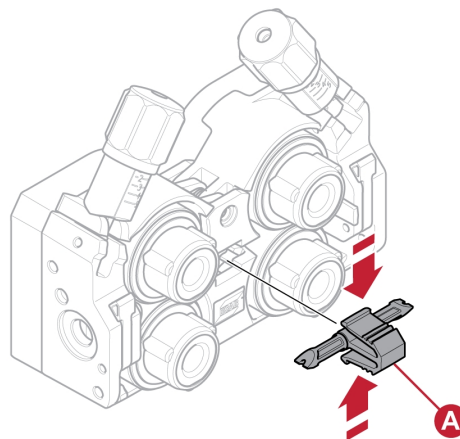
**Wire outlet guide**

- 1) To remove the wire outlet guide, release the pressure on the front feed roll pressure arm by rotating the front tensioner arm outward.
- 2) Remove the lower front feed roll.
- 3) Remove the middle wire guide.
- 4) Unlock the wire outlet guide quick lock (A) by folding it out.
- 5) Remove the wire outlet guide (B).

- 6) Install the new wire outlet guide.
- 7) Lock the new wire outlet guide into place using the wire guide quick lock (A).
- 8) Reinstall the middle wire guide.
- 9) Reinstall the lower front feed roll.

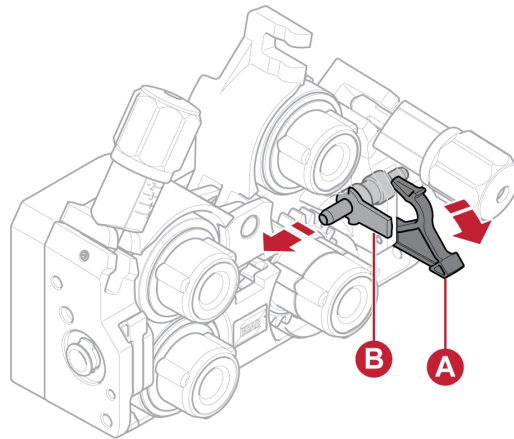

5.13 Setting feed roll pressure

The feed roll pressures should be adjusted independently, determined by the wire type and diameter. The front feed roll pressure should be slightly higher than the rear feed roll pressure.

- 1) Make sure that the wire moves freely through the wire guides and set the feed roll pressure. Do not over tighten.

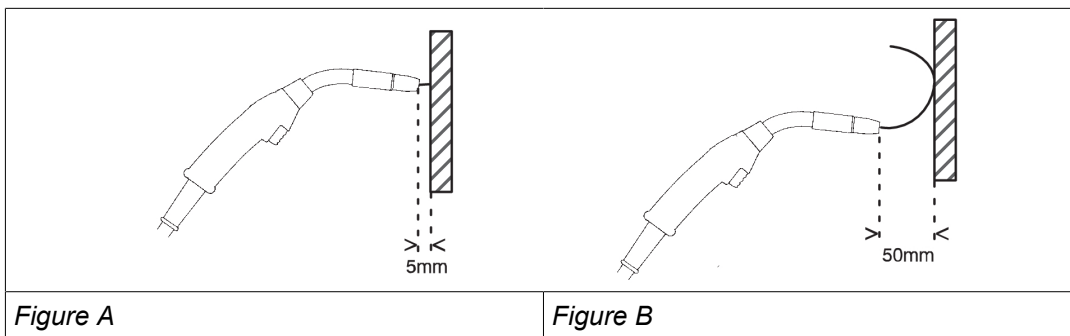

- 2) To check that the feed pressure is set correctly, you can feed the wire against a non-conductive surface. e.g. a piece of wood.

When you hold the welding torch approximately 3/16 in. (5 mm) from the piece of wood (figure A), the feed rolls should slip.

If you hold the welding torch approximately 2 in. (50 mm) from the piece of wood, the wire should feed out and bend (figure B).

The table below serves as a guideline showing approximate Feed roll pressure settings for standard conditions with correct spool brake force. If the torch cables are long, dirty or worn, the pressure setting may need to be increased. Always check the feed roll pressure setting on a case-by-case basis by feeding out the wire against an insulated object as described above.

		Wire diameter (mm) (in.)	0.6	0.8	1.0	1.2	1.4	1.6
			.023	.030	.040	.045	.052	1/16
		Pressure setting						
Wire material	Fe, Ss	Tensioner arm 1	2.5					
		Tensioner arm 2	3–3.5					
	Cored	Tensioner arm 1			2			
		Tensioner arm 2			2.5–3			

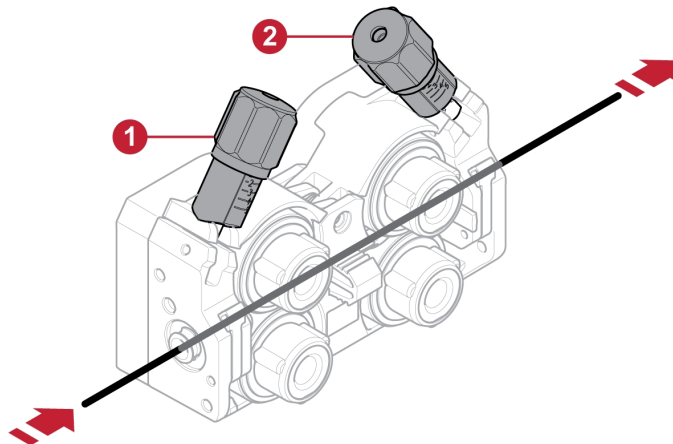

1. Tensioner arm 1

2. Tensioner arm 2

- 3) The wire spool hub incorporates a friction brake. If it is necessary, adjustment can be made by turning the spool locking nut inside the open end of the hub clockwise to tighten the brake. Correct adjustment will result in the wire reel circumference continuing no further than 0.12-0.19 in (3-5 mm) after release of the trigger. The electrode wire should be slack without becoming dislodged from wire spool.

5.14 Shielding gas

The choice of suitable shielding gas depends on the material. Typically, mild steel is welded with mixed gas (Ar + CO₂) or 100% carbon dioxide (CO₂). Stainless steel can be welded with mixed gas (Ar + CO₂) or trimix (He + Ar + CO₂). Aluminum and silicon bronze use pure argon gas (Ar).

5.15 Duty cycle

The duty cycle refers to the time as a percentage of a 10-minute period that you can weld or cut at a certain load without overloading. If this occurs, let the unit cool down for 10 minutes, lower amperage, voltage, or duty cycle before welding.



WARNING!

Exceeding duty cycle can damage power source or torch and void warranty.

Example: If the power source operates at a 40% duty cycle, it will provide the rated amperage for a maximum of 4 minutes out of every 10-minute period. For the remaining time, 6 minutes, the power source must be allowed to cool down.



40%



60%



4 minutes



6 minutes

6 CONTROL PANEL

6.1 User interface

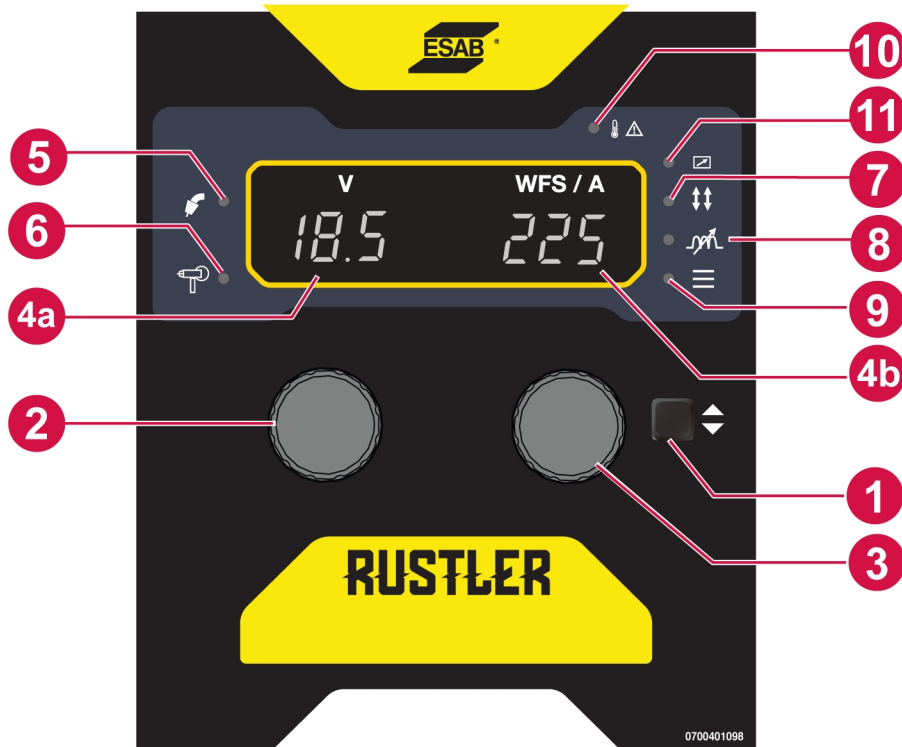

- | | |
|---|---|
| 1. Parameter selection button | 7. Trigger mode |
| 2. Left potentiometer knob | 8. Arc dynamics |
| 3. Right potentiometer knob | 9. Menu indication |
| 4. 4a) Voltage display,
4b) WFS/amperage display | 10. Over temperature indicator |
| 5. GMAW process indicator | 11. Remote indication (used in the conjunction
with spool gun) |
| 6. Spool gun operation indicator | |

6.2 Navigation

Left potentiometer knob

In MIG / MAG / GMAW mode, the knob is used to adjust the weld output voltage of the unit. In manual MIG / MAG / GMAW mode, the setup chart is attached to the wire feed compartment door.

When parameter button or menu is selected, adjusting the left knob (2) selects the different feature and the name is displayed in the left LED.

Right potentiometer knob

In MIG / MAG / GMAW mode, the right knob adjusts the wire feed speed. The optimum wire feed speed required depends on the type of welding application. The setup chart is attached to the wire feed compartment door.

When parameter selection is pressed, the user scrolls through arc dynamics, trigger configuration, and menu. The right potentiometer changes the state or value of the function selected.

Menu

In the menu, there are a number of weld variables to be accessed. To access the weld variables, press the parameter selection button until the menu icon is illuminated. Press this button again to

enter the weld variable menu. The left display shows the variable to adjust and the right display shows the value.

Use the left potentiometer to select the desired weld variable and use the right potentiometer to increase or decrease the values.

**NOTE!**

The list of menu functions varies depending on the application selected.







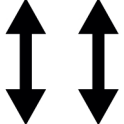

Weld variables

Weld variables provide options to set specific welding variables that can enhance the weld results.

- **Arc dynamics** - used to adjust the intensity of the welding arc. Lower arc dynamics settings make the arc softer with less weld spatter and better wetting action of the weld puddle. Higher arc dynamics settings give a more driving arc which can increase weld penetration. Setting range -9 to +9.
- **Preflow time (PRG)** - the time during which shielding gas flows before the arc is struck. Preflow can improve arc start and purge the immediate weld area of atmosphere minimizing the porosity. Setting range 0.0-9.9 s.
- **Creep start (RIN)** - feeds the wire at a lower wire feed speed than preset wire feed speed value, until the wire makes electrical contact with the workpiece, transitioning to preset wire feed speed value. A slower wire speed at the beginning can enhance the arc starts and reduce spatter. Set as percentage of preset wire feed speed.
- **Crater fill (CRA)** - makes a controlled reduction in the weld parameters and reduces the size of the crater at the end of the weld, minimizing pockets and thermal cracking. Setting range: 0.0-9.9s.
- **Burnback time (B_B)** - a time delay between the time when the wire starts to brake until the time when the power source disables the welding output. Too short burnback time will result in a long wire stick out after completion of welding, with the risk of the wire being stuck in the solidifying weld pool. Too long a burnback time results in a shorter stick out, with increased risk of the wire burning back to the contact tip. Setting range 0.01-0.35 s.
- **Postflow time (POG)** - the time during which shielding gas flows after the arc is extinguished. The post-flow will reduce the possibility of porosity, crater cracks and the contamination of the weld puddle as the end of the weld. Setting range 0.0-9.9 s.

6.3 LED indicators description

Indicator	Description
	<p>GMAW</p> <p>Constant voltage control process is where the set voltage and the wire feed speed are set independent of each other.</p>
	<p>2-stroke</p> <p>This indicator blinks in green and displays 2T.</p> <p>With 2-stroke, gas pre-flow starts when the welding torch trigger switch is pressed. The welding process then starts. Releasing the trigger switch stops welding entirely and starts gas post-flow.</p> <p>4-stroke</p> <p>This indicator lit in static green and displays 4T.</p> <p>With 4 stroke, the gas pre-flow starts when the welding torch trigger switch is pressed in and the wire feed and arc starts when it is released. The welding process continues until the switch is pressed in again, the wire feed and arc then stops and when the switch is released the gas post-flow starts.</p>

Indicator	Description
	<p>Arc dynamics</p> <p>Arc dynamics is used to adjust the intensity of the welding arc. Lower settings make the arc softer with less weld spatter. Higher settings give a stronger driving arc which can increase weld penetration.</p>
	<p>Thermal protection</p> <p>The welding power source has overheating protection that trips if the temperature becomes too high. When this occurs, the welding current is interrupted, and an overheating indication lamp is lit. The overheating protection resets automatically when the temperature has fallen within its normal working temperature.</p>
	<p>Measured voltage</p> <p>Measured value in the display for welding voltage V is an average numerical value which is calculated during the welding excluding the weld termination.</p>
	<p>Measured amperage</p> <p>Measured value in the display for welding current A is an average numerical value which is calculated during the weld excluding the weld termination.</p>
	<p>Wire feed speed</p> <p>Measured value in the display for wire feed speed is an average numerical value.</p>
	<p>Menu</p> <p>There are basic functions in the menu feature. To access the functions, press the parameter selection button until the menu symbol is on. The left display shows a letter and the right display shows a value. Select the function by pressing the same button. The knob (4) is used to change the value of the selected function. The knob (3) is used to change the different functions</p>
	<p>Remote</p> <p>The remote function enables settings to be adjusted via the remote unit by disabling the external control panel.</p>
	<p>Spool gun</p> <p>This indicator lights up when the spool gun is connected.</p>

2-stroke mode (welding without ending arc)

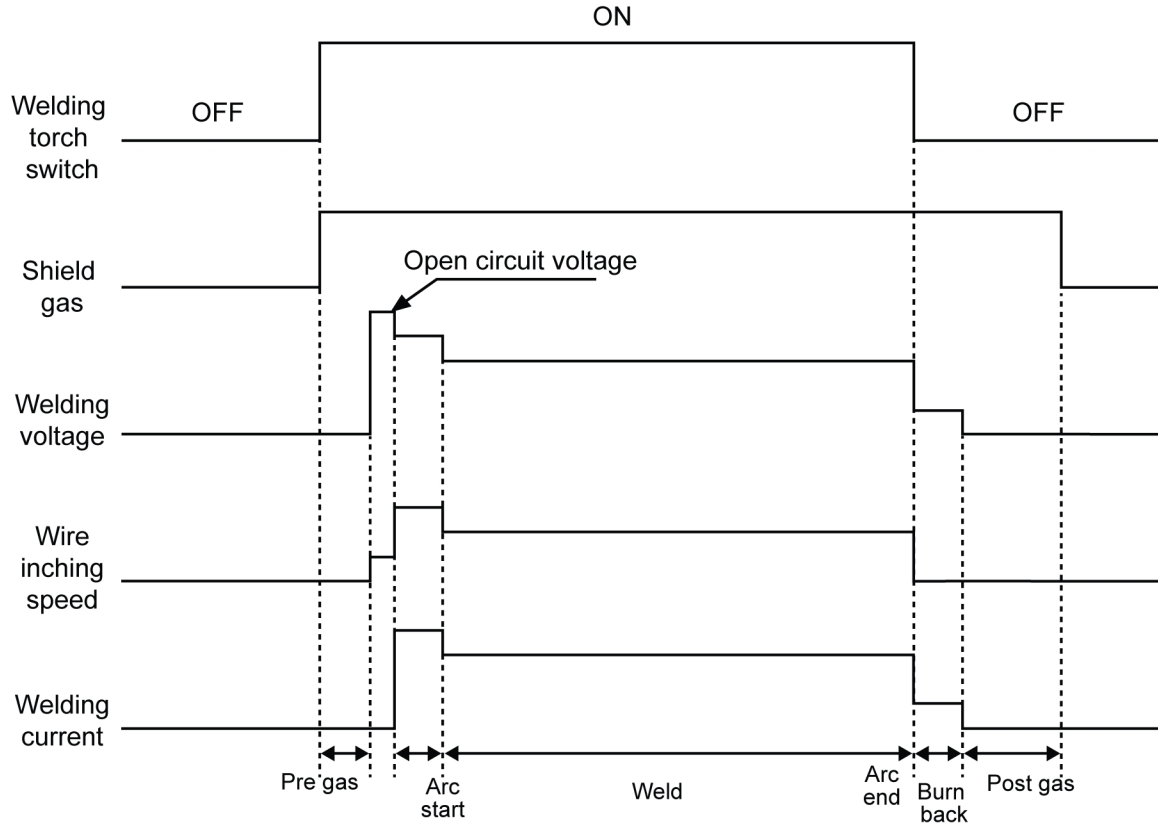

4-stroke mode (welding without ending arc)

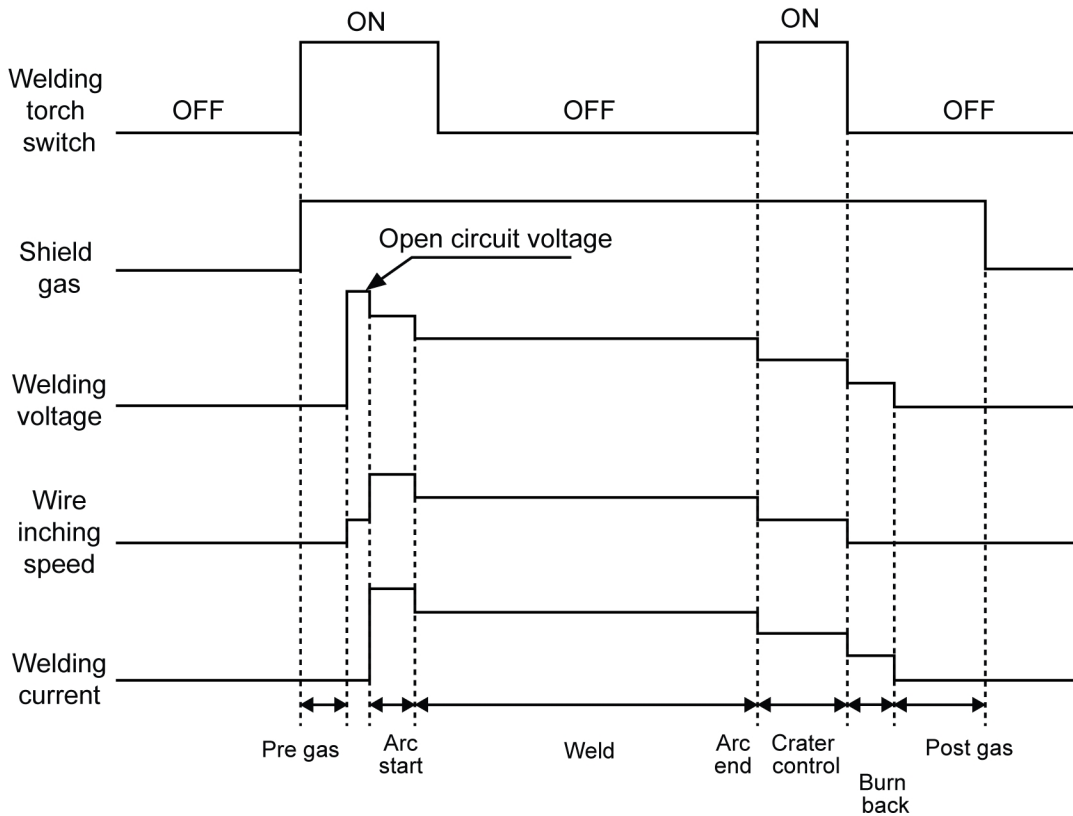

Spot function

The spot function enables the user to set a specific length of weld time each time the torch trigger is depressed. Setting range 0-9.9 s.

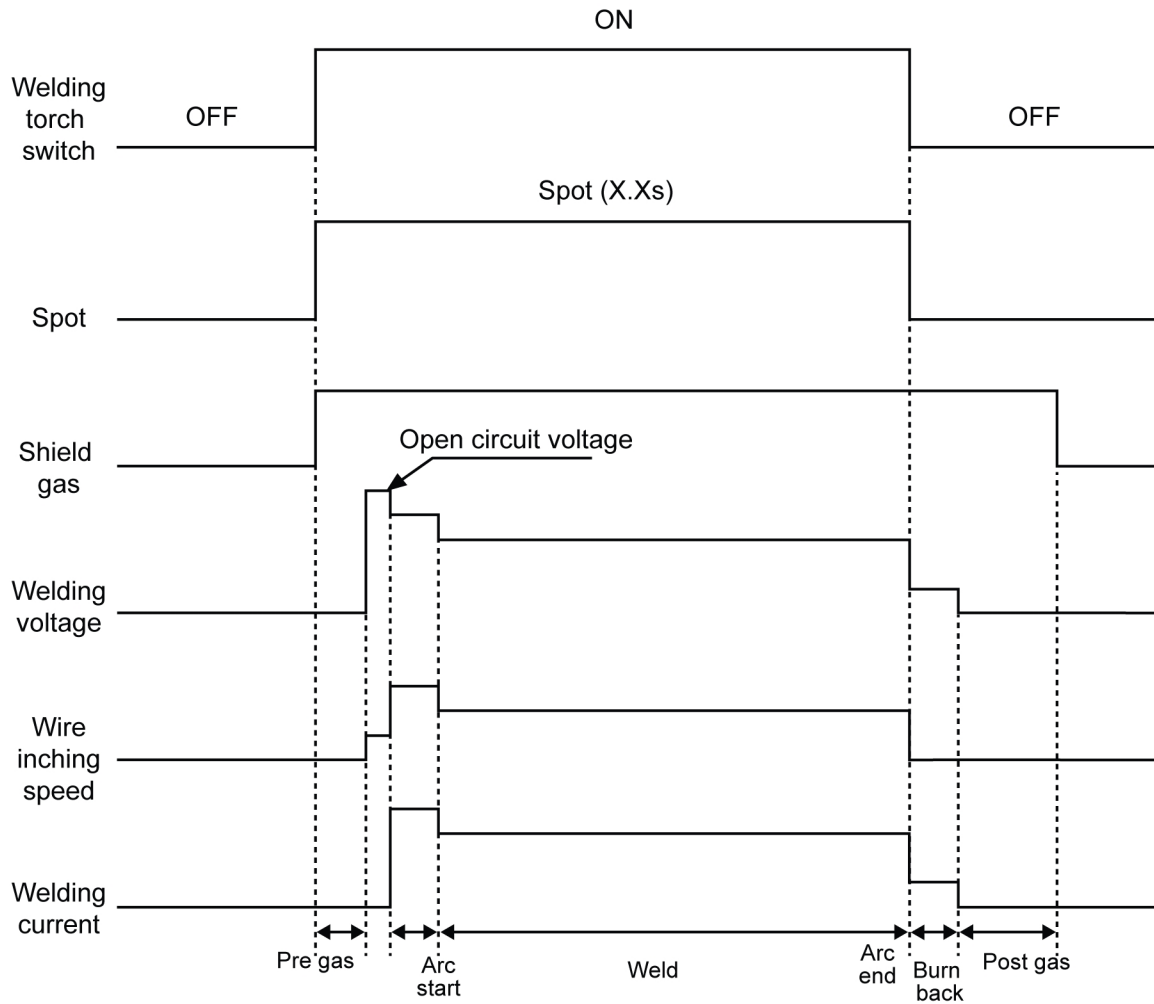

Stitch function

The stitch function enables the user to set two independent times, stitch time (weld time) and dwell time (no weld time). These times (weld, no weld, weld, no weld) will continue as long as the torch trigger is depressed. Stitch time: 0.0-9.9 s and Dwell time: 0.0-9.9 s.

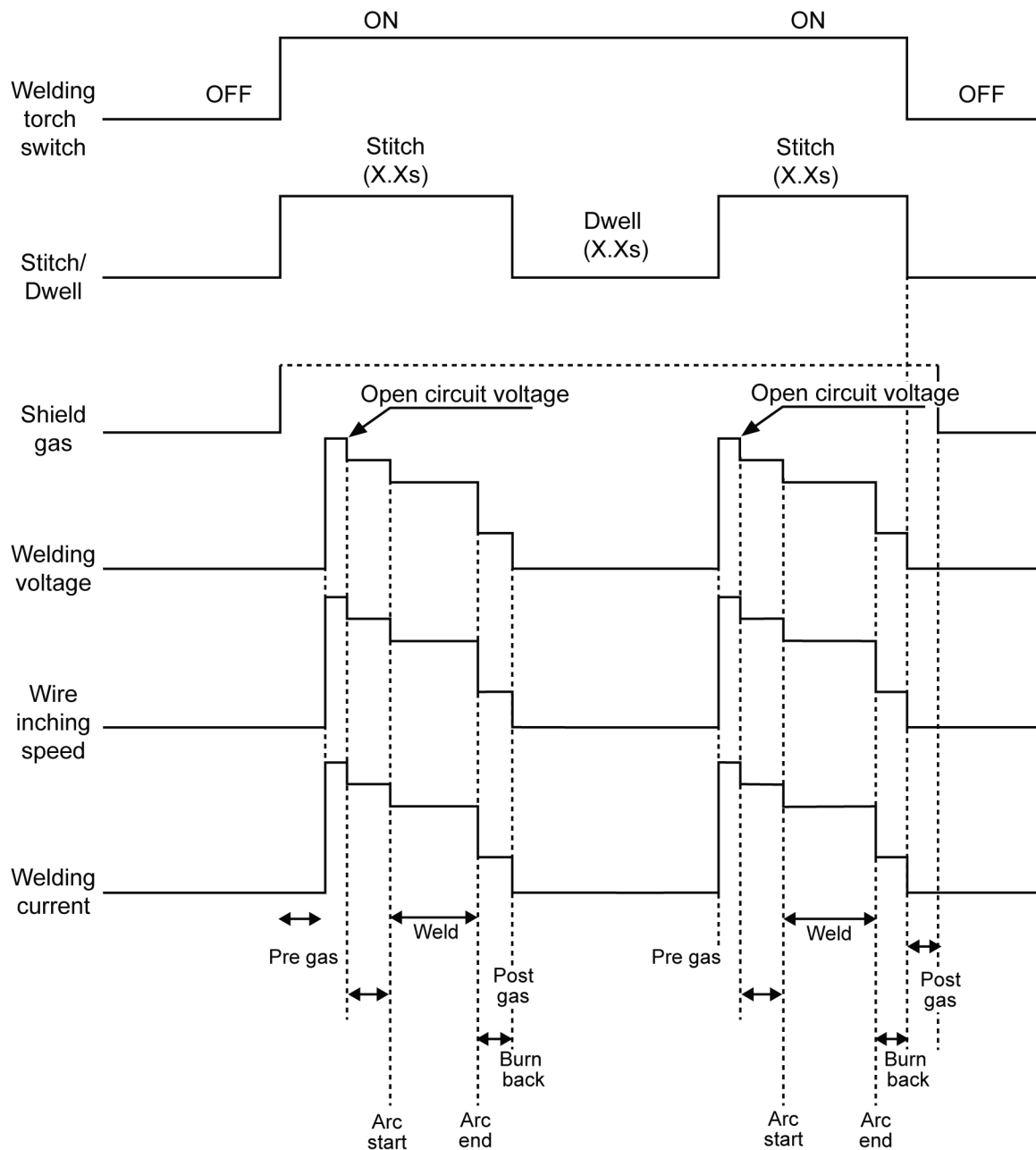

6.4 Menu selection in MIG/MAG/GMAW mode

In MIG/MAG/GMAW mode, press the parameter selection button to navigate to menu option. Select the desired welding function by turning the left potentiometer knob and adjust the desired value by turning the right potentiometer knob.

Left display letter	Function	Default	Right display settings
B-B	Burnback	0.05	0.01-0.35
CRA	Crater fill time	0.0	0.0-9.9
PRG	Pre-flow	0.1	0.0-9.9
POG	Post-flow	0.5	0.0-9.9
SPO	Spot	0	0.0-9.9
STI	Stitch	0	0.0-9.9
DWT	Dwell-time	0	0.0-9.9

Weld process configuration

Long press the parameter selection button to navigate the hidden menu option (no welding). Select the desired function one after the other by turning the left potentiometer knob and adjust the value by turning the right potentiometer knob

Left display letter	Function	Default	Right display settings
RIN	Creep start (run in)	ARC ON	ON/OFF
MAT	Material	Fe	Fe /AL/SS/Cu/FCW
GAS	Gas	MAG	MIX, CO2, Ar, NOG, TMX
DIA	Diameter	0.035	0.030/0.035/ 0.040/0.045
DIS	Display value during welding	WFS	WFS/AMP
UNT	Unit (metric or imperial)	IPM	MPM/IPM
RES	Default settings	No	No/Yes
VEN	Version no	V	-

7 MAINTENANCE

**WARNING!**

The mains supply must be disconnected during cleaning and maintenance.

**CAUTION!**

Only persons with appropriate electrical knowledge (authorized personnel) may remove the safety plates.

**CAUTION!**

The product is covered by manufacturer's warranty. Any attempt to carry out repair work by non-authorized service centers or personnel will invalidate the warranty.

**NOTE!**

Regular maintenance is important for safe and reliable operation.

**NOTE!**





Perform maintenance more often during severe dusty conditions.

Before each use, make sure that the:

- Product and cables are undamaged, and
- The torch is clean and undamaged.

7.1 Routine maintenance

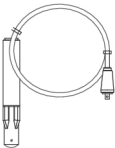
Maintenance schedule during normal conditions. Check equipment before every use.

Interval	Area to maintain		
Every 3 months	 Clean or replace unreadable labels.	 Clean weld terminals.	 Check or replace weld cables.
Every 6 months	 Clean inside equipment. Use dry compressed air with reduced pressure.		

7.2 Cleaning the power source

To maintain the best performance and increase the lifetime of the power source it is mandatory to clean it regularly. How often depends on:

- The welding process,
- The arc time, and
- The working environment.



CAUTION!

Make sure that the cleaning procedure is done in a suitable prepared workspace.



CAUTION!

During cleaning, always wear recommended personal safety equipment, such as ear plugs, safety glasses, masks, gloves, and safety shoes.



CAUTION!

Repair, cleaning, and electrical work should be performed by an authorized ESAB service technician. Use only ESAB original spare and wear parts.

- 1) Disconnect the power source from the power supply.



WARNING!

The mains supply must be disconnected during cleaning and maintenance.

- 2) Remove the screws securing the panels and remove the panels.

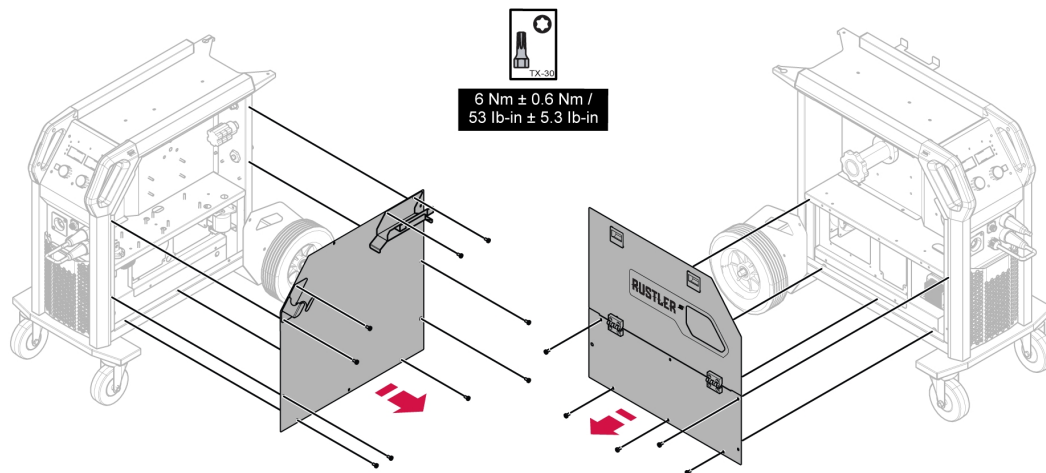

- 3) Clean both sides of the power source, using dry compressed air with reduced pressure of 4 bar (58 psi).
- 4) Make sure that no dust remains on any part of the power source.
- 5) Install both the side panels and tighten the screws with a correct torque specification.

7.3 Inspection, cleaning, and replacement



CAUTION!

Make sure that the cleaning procedure is done in a suitable prepared workspace.



CAUTION!

The cleaning procedure should be carried out by an authorized service technician.

Wire feed mechanism

Check regularly that the wire feed mechanism is not clogged with debris.

- Cleaning and replacement of the wire feed mechanism's worn parts should take place at regular intervals in order to achieve trouble-free wire feeding.



NOTE!

If the wire tensioner is set too high, this can result in abnormal wear on pressure roller's, feed rolls and wire guides.

- Cleaning of the liners and other mechanical parts of the wire feed mechanism should be carried out at regular intervals or if the wire feed seems slow. Use compressed air for this task.
- Changing nozzles.

Bobbin holder

Inspect at regular intervals that the bobbin brake sleeve and the bobbin nut are not worn out and that they lock properly, replace if necessary.

Welding torch

The wear parts of the welding torch should be cleaned and replaced at regular intervals in order to achieve trouble-free wire feed. Regularly blow the wire guide clean and clean the contact tip.

8 ERROR CODES

The error codes are used to indicate that a fault has occurred in the equipment. Errors are indicated by the text "Err" followed by the error code number shown in the display.

Screens



8.1 Error code descriptions

Error codes that the user can handle are listed below. If any other error code appears, contact an authorized ESAB service technician.

Error code	Description
Err 002	<p><i>Torch trigger-related error</i></p> <p>The torch trigger is pressed all the time or the torch trigger signal is short circuit and the ARC is also not established.</p> <p>Action: Release the trigger.</p>
Err 206	<p><i>Temperature fault</i></p> <p>The temperature of the power source is too high. An LED indicating temperature fault is also illuminated on the panel. A temperature fault is indicated by the overheating indicator on the control panel.</p> <p>Action: The error code will automatically disappear and the LED indicating temperature fault will be turned off when the power source has cooled down and is ready for use again. If the error persists, contact a service technician.</p>
Err 215	<p><i>Output short circuit</i></p> <p>Short circuit is detected during output activation fault trigger.</p> <p>Action: Remove short circuit condition.</p>
Err 216	<p><i>Over output current</i></p> <p>The output amps over design limitation.</p> <p>Action: Reduce settings and resume welding.</p>

9 TROUBLESHOOTING

Perform these checks and inspections before sending for an authorized service technician.

Check that power is disconnected before starting any type of repair action.

Type of fault	Corrective action
Porosity within the weld metal	Check that the gas bottle is not empty.
	Check that the gas regulator is not closed.
	Check gas inlet hose for leaks or blockage.
	Check that the correct gas is connected and the correct gas flow is used.
	Keep the distance between the GMAW torch nozzle and the work piece to a minimum.
	Do not work in areas where drafts, which would disperse the shielding gas, are common.
	Make sure the work piece is clean, with no oil or grease on the surface, before welding.
MIG/MAG/GMAW welding problems	Make sure the torch is connected to the correct polarity.
	Replace contact tip if it has arc marks in the bore causing excessive drag on the wire.
	Make sure the correct shielding gas, gas flow, voltage, welding current, travel speed and torch angle are used.
	Make sure the work lead has proper contact with the work piece.
No arc	Check that the main power supply switch is turned on.
	Check that the mains, welding and return cables are correctly connected
	Check that the correct current value is set.
	Check the electrical power supply fuses.
Thermal protection trips frequently	Make sure that you are not exceeding the rated data for the power source (i.e. that the unit is not being overloaded).
	Check that the ambient temperature is not above the one for the rated duty cycle 40°C/104°F.
Poor welding performance	Check that the welding current supply and return cables are correctly connected.
	Check that the correct current value is set.
	Check that the correct welding wires are being used.
	Check the main power supply fuses.
The wire feed is slow/stiff through the wire feed mechanism	Clean the liners and other mechanical parts of the wire feed mechanism using pressurized air.
	Clean and adjust the roller pressure as per the table on the decal on the left side door.

10 ORDERING SPARE PARTS



CAUTION!

Repair and electrical work should be performed by an authorized ESAB service technician.
Use only ESAB original spare and wear parts.

Rustler EM 280 PRO is designed and tested in accordance with the international standards **ANSI/NEMA/IEC 60974-1 & CSA C22.2 no. 60974-1**. Upon completion of service or repair work, it is the responsibility of the person(s) performing the work to ensure that the product still complies with the requirements of the above standards.

Spare parts and wear parts can be ordered through your nearest ESAB dealer, see esab.com. When ordering, please state product type, serial number, designation and spare part number in accordance with the spare parts list. This facilitates dispatch and ensures correct delivery.

The spare parts list is published in a separate document that can be downloaded from the Internet:
www.esab.com

APPENDIX

WIRING DIAGRAM

Rustler EM 280 PRO

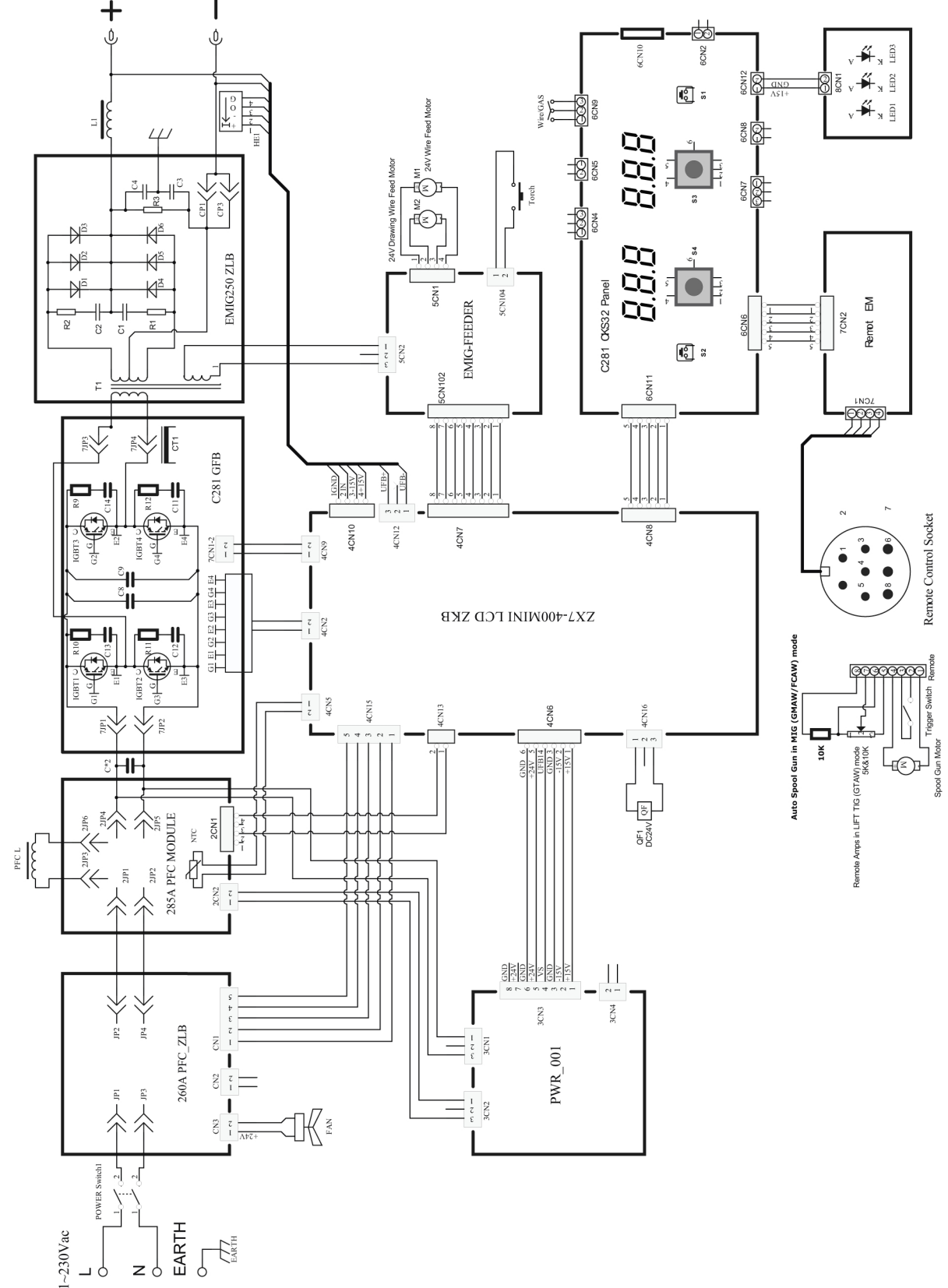

ORDERING NUMBERS

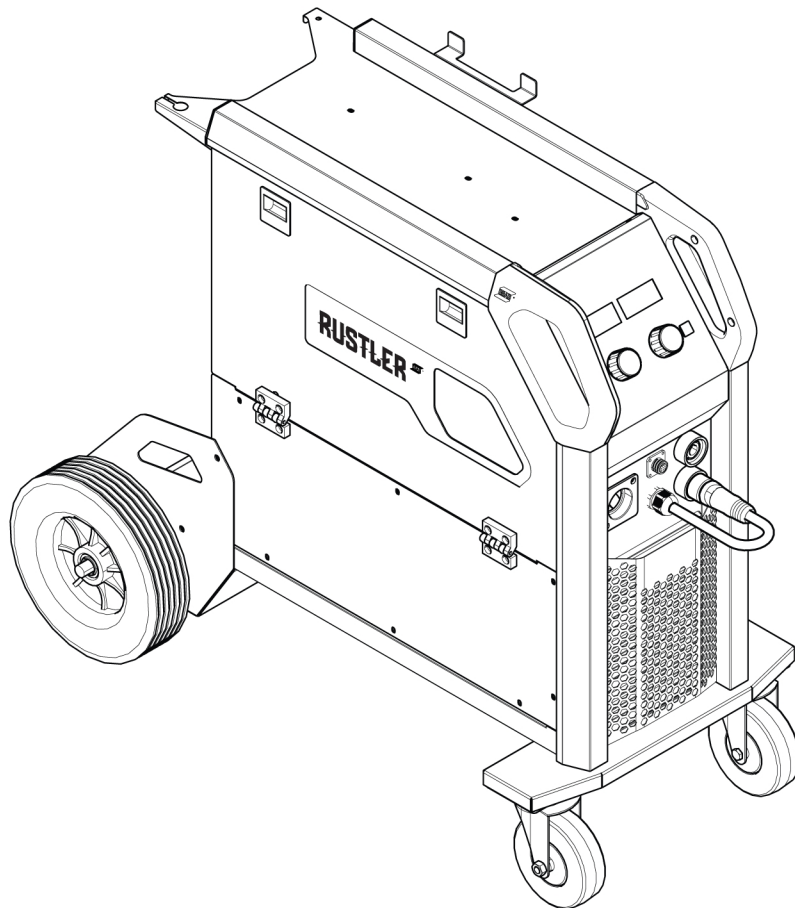

Ordering number	Denomination	Notes
0700 401 201	Rustler EM 280 PRO	208 V / 230 V \pm 15%, 1 Φ 50/60 Hz, NAM
0448 534 *	Instruction manual	
0448 533 001	Quick start guide	

The three last digits in the document number of the manual show the version of the manual. Therefore they are replaced with * here. Make sure to use a manual with a serial number or software version that corresponds with the product, see the front page of the manual.

Technical documentation is available on the Internet at: www.esab.com

WEAR PARTS

Spray Master™ 250 V

Contact tip		
Part no.	Size in. (mm)	
1160-1751	0.030 (0.8)	
1160-1752	0.035 (0.9)	
1160-1754	0.045 (1.2)	
1160-1756	0.052 (1.4)	
1160-1757	0.062 (1.6)	
1160-1755	0.045 (1.2), Al	

Nozzle		
Part no.	Size in. (mm)	
1240-1854	0.625 (15.9), Recess	
1240-1855	0.625 (15.9), Flush	
1240-1852	0.752 (19.1), Recess	
1240-1853	0.752 (19.1), Flush	

Conduit / liner		
Part no.	Size in. (mm)	
1440-1113	0.035/0.045 (0.9/1.2), Fe	
1440-1123	0.052/0.062 (1.4/1.6), Fe	
1440-1003	0.030/0.045 (0.8/1.2), Al	
1440-1012	0.062 (1.6), Al	

Feed rolls

V-groove			
Part no.	Size in. (mm)		
0445850001	0.024 (0.6)	0.030 (0.8)	
0445850003	0.035 (0.9)	0.035 (0.9)	
0445850004	0.035 (0.9)	0.045 (1.2)	
0445850005	0.045 (1.2)	0.045 (1.2)	
0445850006	0.052 (1.4)	0.062 (1.6)	

V-K-knurled			
Part no.	Size in. (mm)		
0445850030	0.035 (0.9)	0.045 (1.2)	
0445850032	0.045 (1.2)	0.052 (1.4)	

U-groove			
Part no.	Size in. (mm)		
0445850050	0.030 (0.8)	0.035 (0.9)	
0445850051	0.035 (0.9)	0.045 (1.2)	









Wire guide

Wire inlet guide				
Part no.	Wire	Size in. (mm)		
0445822001	Fe/SS/C	0.024 (0.6)	0.062 (1.6)	
0445080882	Al	0.030 (0.8)	0.062 (1.6)	

Wire intermediate guide				
Part no.	Wire	Size in. (mm)		
0446080882	Fe/SS/C	0.024 (0.6)	0.062 (1.6)	
0446080881	Al	0.030 (0.8)	0.062 (1.6)	

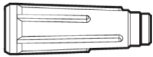
Wire outlet guide				
Part no.	Wire	Size in. (mm)		
0445830881	Fe/SS/C	0.024 (0.6)	0.062 (1.6)	
0445830885	Al	0.030 (0.8)	0.062 (1.6)	

ACCESSORIES

1023-1277	Spray Master Velocity 250V MIG gun 12 ft. (3.6 m)	
0558103111	Work lead with clamp 300 A, 2 AWG (35 mm ²) 15 ft. (4.6 m)	
1027-1494	Spool gun 250, OKC 50 8p 4 m (12.5 ft)	
1027-1495	Spool gun 250, OKC 50 8p 7.6 m (25 ft)	
9425-1431	OKC 50 cable connector, male (2 ea.)	
9425-1432	OKC 50 cable connector, female (2 ea.)	
0700400858	Gas hose 5/8 in 18 RH fittings, 13.1 ft. (4.0 m)	
0781-9411	Victor GF-250-50-580 flow gauge regulator for Ar/CO ₂	
0781-2703	Victor GRF400-320 flow gauge regulator for CO ₂	



A WORLD OF PRODUCTS AND SOLUTIONS.



For contact information visit esab.com

ESAB Corporation, 2800 Airport Road Denton, TX 76207, USA, Phone +1 800 378 8123

manuals.esab.com

